

<b>System Model</b>	<b>ES-60LS3-445</b>	
<b>System Performance</b>	<b>Metric</b>	<b>British</b>
<b>Rated Random/Sine Force</b>	60 kN	13200 lbf
<b>Rated Shock Force</b>	120/180* kN	26400/39600* lbf
<b>Usable Frequency</b>	5-2700 Hz	5-2700 Hz
<b>Maximum Velocity</b>	2/2.5* m/s	78.7/98.4* in/s
<b>Maximum Acceleration</b>	1000 m/s <sup>2</sup>	100 g
<b>Maximum Payload</b>	800 kg	1760 lbs
<b>Resonance Frequency</b>	2300±5% Hz	2300±5% Hz
<b>Maximum Displacement p-p</b>	76 mm	3 in
<b>Shaker Model</b>	<b>ET-60LS3</b>	
<b>Mass of Moving Elements</b>	55 kg	121 lbs
<b>Armature Diameter</b>	445 mm	17.5 in
<b>Weight</b>	About 4500 kg	About 9921 lbs
<b>Body Suspension Natural Frequency</b>	2.5 Hz	2.5 Hz
<b>Dimension L×W×H</b>	1700×1130×1246 mm	66.9×44.5×49.3 in
<b>Power Amplifier Model</b>	<b>DA-60</b>	
<b>Power</b>	60 kVA	60 kVA
<b>Weight</b>	About 700 kg	About 1543 lbs
<b>Power Supply Requirement</b>	95 kVA	95 kVA
<b>Dimension L×W×H</b>	610×850×1983 mm	24×33.5×78 in
<b>Cooling Type</b>	<b>Air Cooling</b>	
<b>Blower Model</b>	<b>B-7000</b>	
<b>Power</b>	22 kW	29.5 hp
<b>Air Flow</b>	1.6 m <sup>3</sup> /s	1600 l/s
<b>Air Pressure</b>	8 kPa	1.16 psi
<b>Weight</b>	340 kg	750 lbs

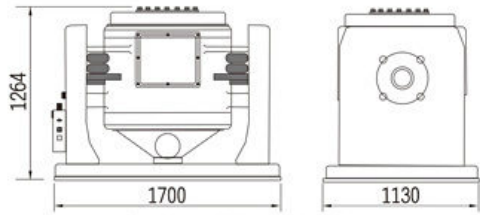

Shaker ET-50/60LS3-445

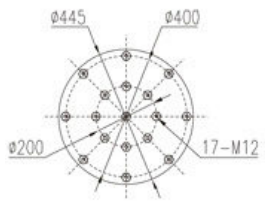
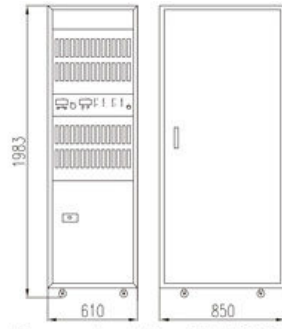

Power Amplifier DA-50/60

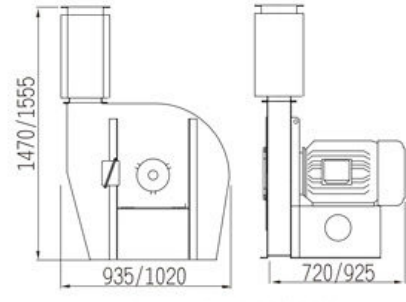

Blower B-5000/7000